



TECHNICAL BULLETIN TB-024a

TS4085 CONNECTION PROCEDURE

DESCRIPTION

The new Davicom TS4085 temperature sensor replaces the previous S-TEMP sensor device (see TB-004b). The TS4085 unit is available in both indoor (TS4085-I) and outdoor (TS4085-O) versions, and has a temperature measurement range of -40°C to $+85^{\circ}\text{C}$ (-40°F to $+185^{\circ}\text{F}$). Typical measurement accuracy is $\pm 1^{\circ}\text{C}$ ($\pm 1.8^{\circ}\text{F}$).

Designed as an add-on for the Davicom DV-series of remote monitoring units, the TS4085 can however be used with other equipment. Screw-mounting holes allow both versions to be easily attached to typical wood and metal surfaces.

Values given in the following instructions apply to temperature sensor units with serial numbers ST16385-94 and higher. Please refer to Technical Bulletin TB-004b for data on earlier S-TEMP units.

The nominal supply voltage for the TS4085 is +12Vdc, but all units will operate with input voltages from +6Vdc to +15Vdc. Its typical output signal varies from +0.85Vdc to +2.05Vdc over the -40°C to $+85^{\circ}\text{C}$ temperature range.

INDOOR MODEL (TS4085-I)

There are three user connections on the TS4085 indoor unit: +12, OUT, and GND. When used with the DV-Mini or DV-208/216 the +12 and GND connections can be taken from the 12Vdc power supply terminals. The OUT terminal can be connected to any desired metering input (Axx).

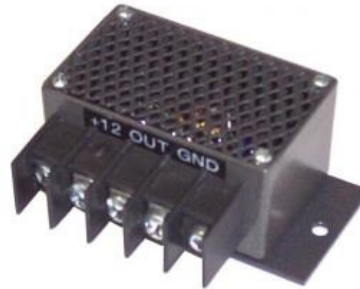

The TS4085-I can be attached to any convenient wood or metal surface.

OUTDOOR MODEL (TS4085-O)

The outdoor model has an integrated 3-wire, shielded cable for power and signal connections: red wire for +12, white wire for OUT, and black wire for GND. Power and signal connections are the same as those for the indoor model.



To install the TS4085-O, follow the installation instructions on the next page.

OUTDOOR MODEL INSTALLATION

The outdoor model comes complete with a PVC collar clamp having 1/4" holes for a typical wall mount installation using #10 screws (not supplied).

Install the outdoor TS4085 (1) with PVC clamp (2) and rubber spacers (3), as shown in the figure, making sure that the drain holes are located at the bottom.

Do not over-tighten the mounting screws.

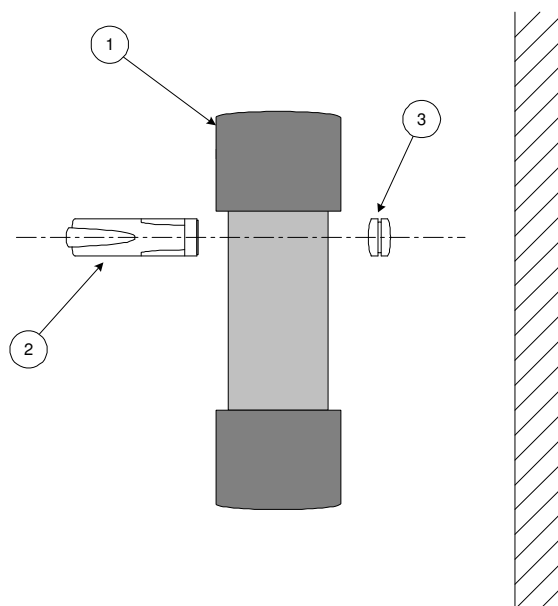



TECHNICAL BULLETIN TB-024a

TS4085 CONNECTION PROCEDURE

DV-Mini CONNECTION PROCEDURE

1. Use DavLink to connect to the DV-Mini unit, and select the metering input (Axx) to be used with the TS4085. Configure the Axx input parameters as desired, and set the voltage scale to 2.5.

2. Next, set the metering input sensor coefficients.

For the Celsius scale, sensor coefficients must be set to: A=0, B=100, C=-125 and D=0.

For the Fahrenheit scale, sensor coefficients must be set to: A=0, B=180, C=-193 and D=0.

Note the negative sign of the C coefficient. Refer to the Davicom Reference Manual for specific details on configuring metering input parameters.

3. Connect the TS4085 +12V terminal (or red wire) to the +12Vdc supply terminal of the DV-Mini.
4. Connect the TS4085 GND terminal (or black wire) to a DV-Mini AGND connection point.
5. Connect the TS4085 OUT terminal (or white wire) to the Axx input selected in step 1.
6. In DavLink, select the metering input used with the TS4085. The Axx value displayed in the Global View window (or on the analog meter) is the temperature reading given by the sensor.

DV-208/216 CONNECTION PROCEDURE

1. Use DavLink to connect to the DV-208/216 unit, and select the metering input (Axx) to be used with the TS4085. Configure the Axx input parameters as desired, and set the voltage scale to 2.5. You must also set the corresponding Axx jumper on the signal conditioning board for the 2.5 volt scale.

2. Next, set the metering input sensor coefficients.

For the Celsius scale, sensor coefficients must be set to: A=0, B=100, C=-125 and D=0.

For the Fahrenheit scale, sensor coefficients must be set to: A=0, B=180, C=-193 and D=0.

Note the negative sign of the C coefficient. Refer to the Davicom Reference Manual for specific details on configuring metering input parameters.

3. Connect the TS4085 +12V terminal (or red wire) to the +12Vdc supply terminal of the DV-208/216.
4. Connect the TS4085 GND terminal (or black wire) to a DV-208/216 unit AGND connection point.
5. Connect the TS4085 OUT terminal (or white wire) to the Axx+ input selected in step 1.
6. Connect the DV-208/216 unit Axx- input to AGND to ensure unipolar operation.
7. In DavLink, select the metering input used with the TS4085. The Axx value displayed in the Global View window (or on the analog meter) is the temperature reading given by the sensor.

NOTE

Refer to the Davicom technical documentation for rear-panel-connector pinout information.